

# TIGERGRIP | TG 28 UG-11

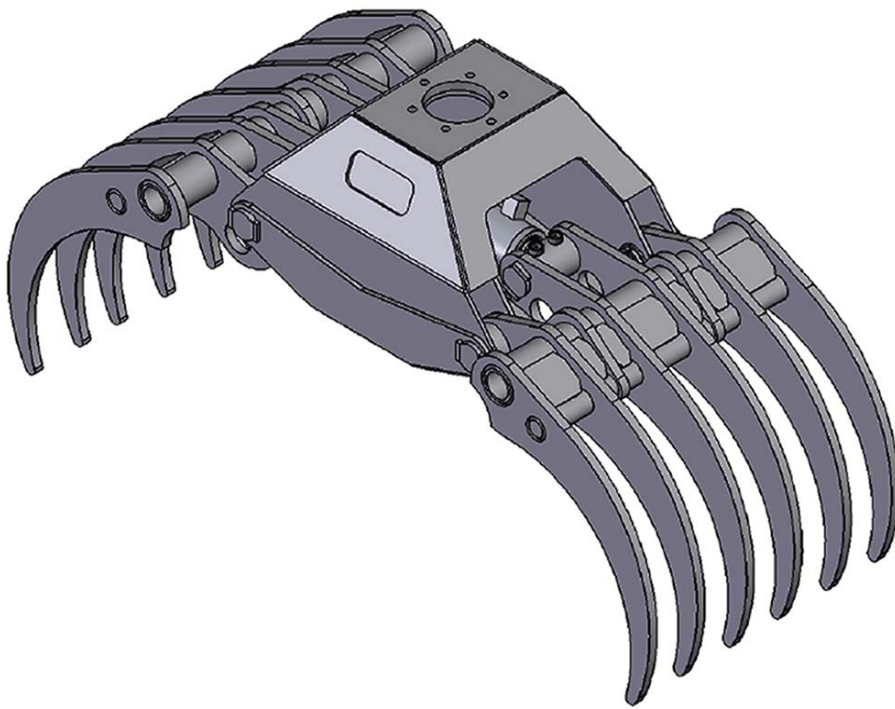

## KEY FEATURES

- Heavy duty
- Double guide bars
- Optimized roll in/roll out properties
- High pressure cylinder with double piston rod seals
- High tensile wear resistant steel (400 HB)
- Extra reinforced body for rigid mounting - excavator design

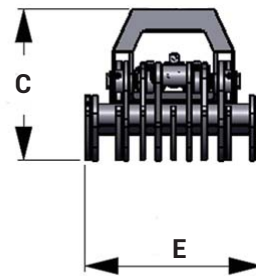
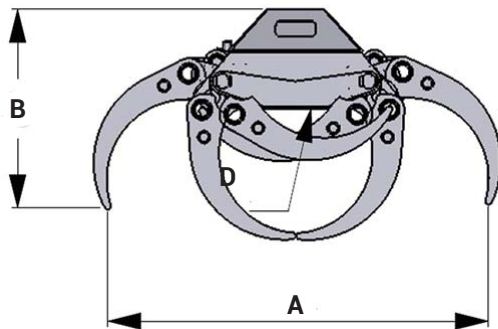

<b>A</b>	1520
<b>B</b>	788
<b>C</b>	604
<b>D</b>	90
<b>E</b>	730

## MODEL SPECIFICATIONS



TG 28 UG-11

440

0,28

300

60

16,6

15

5

15

10

# INTERMERCATO

High performance lift and load attachments for Forestry, Transport, Construction and Recycling.

