

H 132 LS

Part No.: 7212088

- Load Sense¹

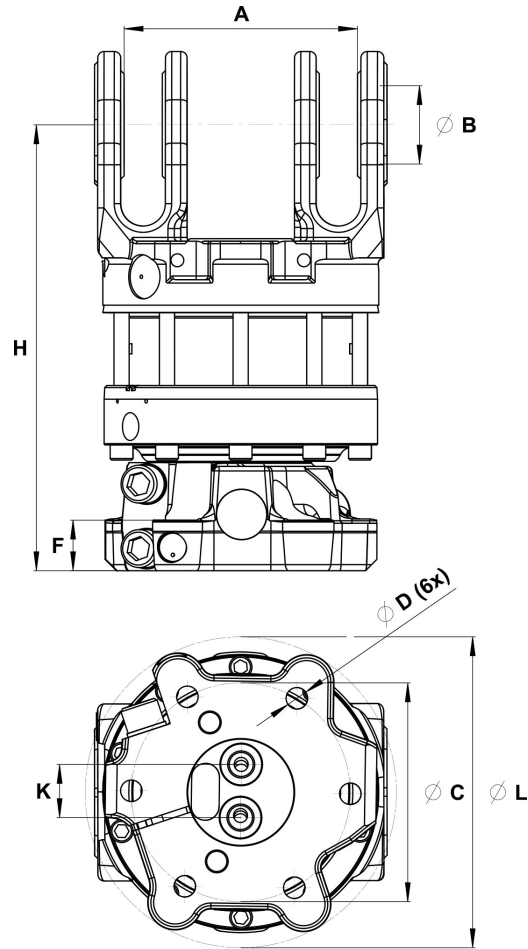
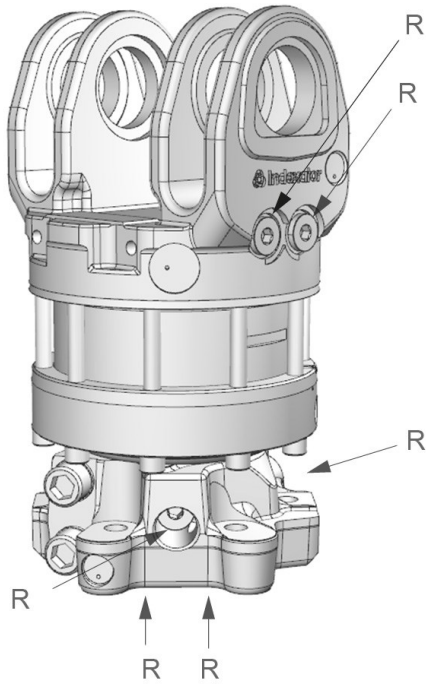

Upper connection	Lower connection
G 1/2	G 1/2

A: MPB2	B: MPB	C: Ø173 mm	D: Ø17 mm	F: 40 mm	H: 352 mm	K: 42 mm	L: Ø248 mm
------------	-----------	---------------	--------------	-------------	--------------	-------------	---------------

		Max 	Max 		Max 	Max 
62.8 kg	360°	100 kN	50 kN	2200 Nm	25 l/min	25 MPa

¹ A rotator with the shortening LS is not equipped with restrictors (unlike our standard rotators). This means that the oil flow from the base machine has to be adapted.

Rotator suitable for MPB swing dampers.

Adapter sets are available for alternative connections.

For further technical information relating to integration and hydraulic connections, please contact rotator@indexator.com