

# INDUSTRIAL ROTATOR GIR25-04

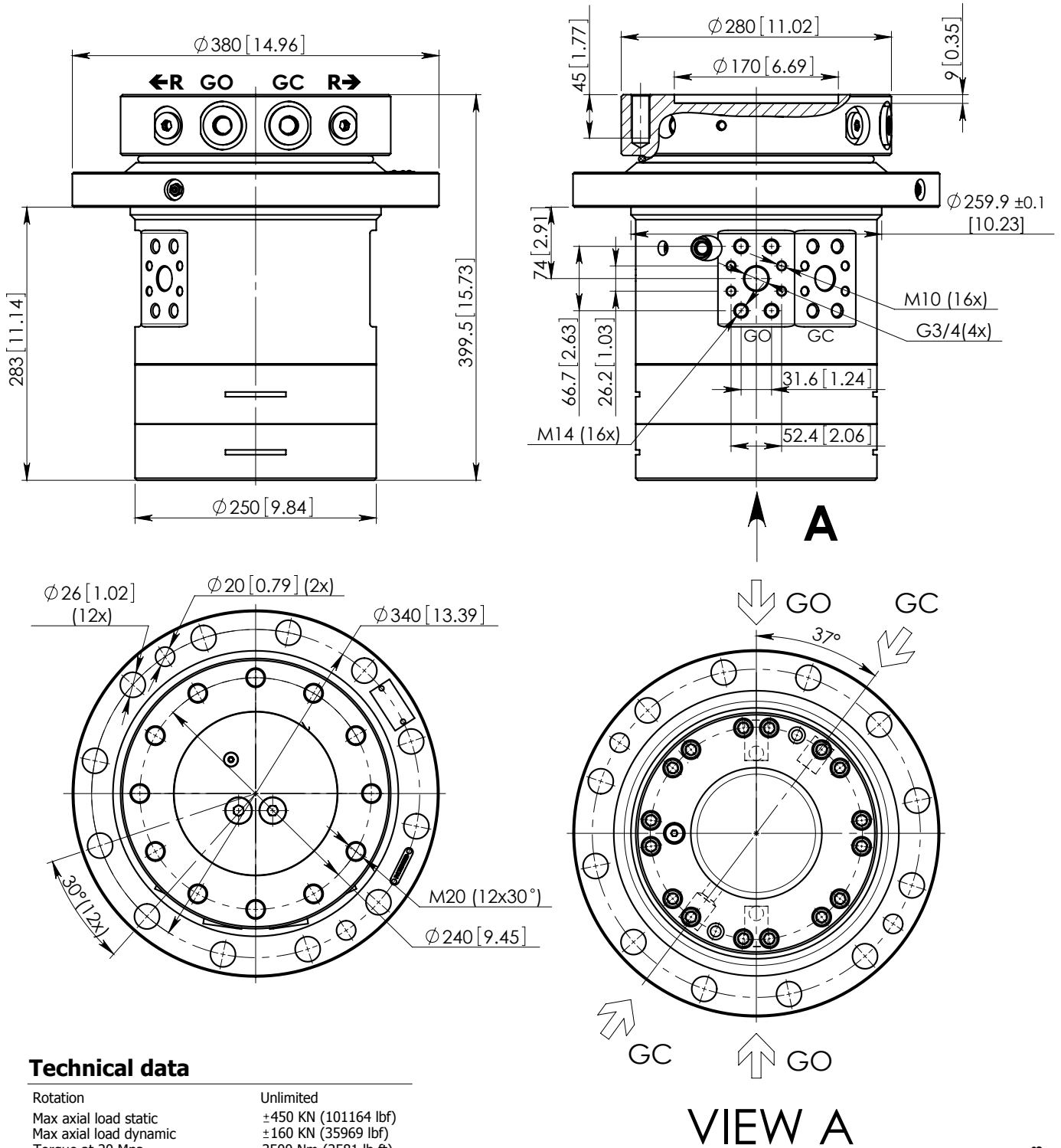

## Technical data

Rotation	Unlimited
Max axial load static	±450 kN (101164 lbf)
Max axial load dynamic	±160 kN (35969 lbf)
Torque at 20 Mpa	3500 Nm (2581 lb ft)
Rated displacement	1304 cm <sup>3</sup> /rev
Rotation speed	max 25 rpm
Oil duct area for grapple	260 mm <sup>2</sup> (0.403 in <sup>2</sup> )
Weight	143 kg (315 lb)

Function	Max working pressure	Rec oilflow	Connections	Operating machine e.g. excavator max weight
<b>R</b> - rotation	20 MPa (2901 psi)*	35l/min	G 1/2	Connected via link 18 t
<b>GO</b> - grapple/tool open	32 MPa (4641 psi)*		G 3/4, SAE 1 1/4, SAE 1	
<b>GC</b> - grapple/tool close	32 MPa (4641 psi)*		G 3/4, SAE 1 1/4, SAE 1	

\* Relief valve fitted