

# XR 400 P

Part No.: 8400014

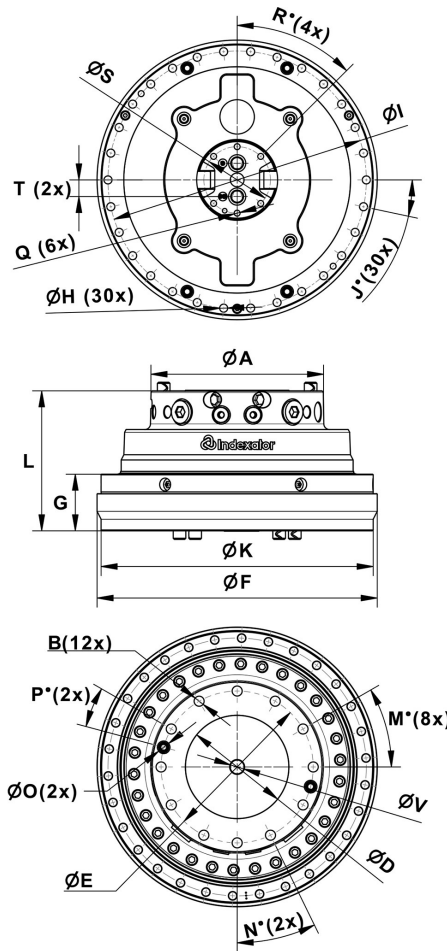
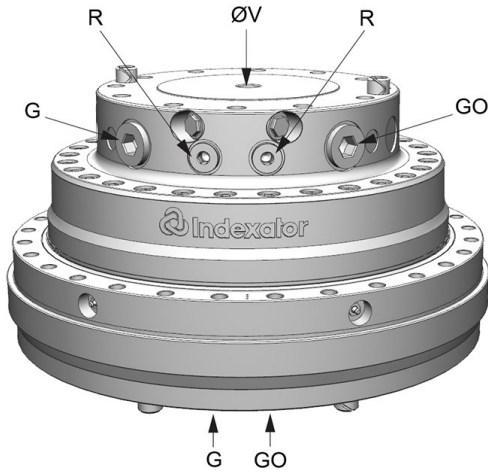

## Upper

G GO:	R:
G 1	G 1/2

A: Ø300 mm	B: M20	D: Ø170 mm	E: Ø265 mm	F: Ø488 mm	G: 99 mm	H: Ø14 mm	I: Ø450 mm	J: 12°	K: Ø474 mm	L: 244 mm	M: 30°	N: 26°	O: Ø22 mm
P: 15°	Q: M12	R: 45°	S: Ø116 mm	T: 29 mm	V: Ø24 mm								

179 kg	360°	±550 kN	±200 kN	±140 kN	4100 Nm	35 l/min	25 MPa	40 MPa	40 MPa

Rotator with a centred hole for e.g. wiring.

Oil distributor ordered separately

Pressure limiting valves fitted.

For further technical information relating to integration and hydraulic connections, please contact [rotator@indexator.com](mailto:rotator@indexator.com)