

# TIGERGRIP / TG 16 ST

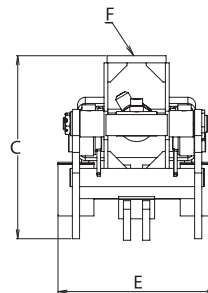

## KEY FEATURES

- Heavy duty
- Double guide bars
- Optimized roll in/roll out properties
- High tensile wear resistant steel (400 HB)
- Extra reinforced body for rigid mounting - excavator design

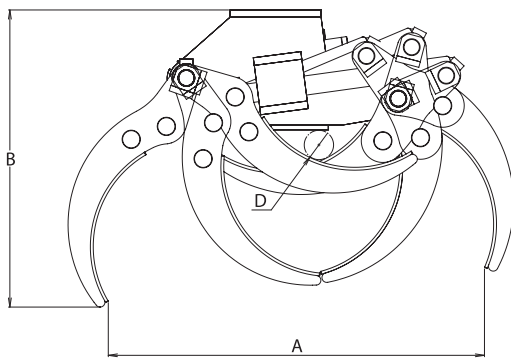

<b>A</b>	785
<b>B</b>	520
<b>C</b>	387
<b>D</b>	55
<b>E</b>	330
<b>F</b>	140x140

## MODEL SPECIFICATIONS



TG 16 ST

65

0,16

200

40

9

3

1

3

2

# INTERMERCATO

High performance lift and load attachments for Forestry, Transport, Construction and Recycling.

